



**LARK 100 Wireless
Microphone
User Manual**

Preface

The purpose of this section is to ensure that the user is able to use the product correctly through this manual in order to avoid danger in operation or property damage. Before using this product, please read the product manual carefully and keep it for future reference.



Outlined

This manual applies to LARK Wireless Microphone.

This manual describes the functions and use of the various functional modules of the LARK Wireless Microphone, and guides you through the installation and commissioning of the LARK Wireless Microphone.

Symbol Conventions

The symbols that may be found in this document are defined as follows.

Symbol	Description
 Note	Provides additional information to emphasize or supplement important points of the main text.
 Caution	Indicates a potentially hazardous situation, which if not avoided, could result in equipment damage, data loss, performance degradation, or unexpected results.
 Danger	Indicates a hazard with a high level of risk, which if not avoided, will result in death or serious injury.

Safety Instructions

Danger

To ensure reliable use of the equipment and the safety of personnel, please observe the following during installation, use and maintenance:

- During the installation and use of the equipment, all electrical safety regulations of the country and the region of use must be strictly observed.
- When installing the equipment, make sure that the input power of the equipment power adapter is 100V-240V, 50/60Hz AC power.
- Keep the working environment well ventilated so that the heat generated by the equipment during operation can be discharged in time to avoid damage to the equipment due to excessive temperature.

- Always unplug the unit's power adapter from the AC power outlet before: A. Removing or reinstalling any part of the equipment; B. Disconnecting or reconnecting any electrical plug or connection of the equipment. Do not operate with electricity.
- There are AC high-voltage parts in the equipment, non-professionals should not disassemble them without permission to avoid the risk of electric shock. Do not repair the equipment privately to avoid aggravating the damage.
- Do not spill any corrosive chemicals or liquids on or near the equipment.
- If the unit emits smoke, odour or noises, turn off the power immediately and unplug the power cord, and contact your dealer or service centre.
- If the appliance is not working properly, contact the shop where you purchased the appliance or the nearest service centre and do not disassemble or modify the appliance in any way. (We cannot be held responsible for problems caused by unapproved modifications or repairs).

**Caution**

- Do not drop objects on the equipment or vibrate the equipment vigorously, and keep the equipment away from locations with magnetic field interference. Avoid installing the equipment in a place where the surface vibrates or is susceptible to shock (neglecting this may damage the equipment).
- Do not use the equipment in high temperature, low temperature or high humidity environments. Refer to the equipment's data sheet for specific temperature and humidity requirements.
- Use the unit indoors, not in an exposed installation where it may be exposed to rain or extreme humidity.
- When the equipment is not used for a long period of time or in a humid and dewy environment, the main power supply of the equipment should be switched off.
- When cleaning the equipment, please use a sufficiently soft dry cloth or other alternatives to wipe the internal and external surfaces, do not use alkaline detergent to wash, and avoid hard objects to scratch the equipment.
- Please keep all the original packaging materials of the equipment properly, so that in case of problems, use the packaging materials to pack the equipment and send it to the agent or return it to the manufacturer for processing. We will not be responsible for any accidental damage in transit not caused by the original packaging materials.

**Note**

- Basic knowledge and skills in low voltage cabling and wiring of low voltage electronics.
- Basic audio and networking knowledge and skills and the ability to read and understand the contents of this manual.

TABLE OF CONTENTS

Chapter 1 Product Introduction	1
1.1 Appearance	1
1.2 Introduction	1
1.3 Product Features	1
Chapter 2 Usage Scenarios	2
2.1 General classroom sound reinforcement scenes	2
2.2 Lecture theatre sound reinforcement Scenes	3
Chapter 3 Operating Instructions	4
3.1 Usage Process	4
3.2 Transmitter Instructions	4
3.3 How to Wear the Transmitter	5
3.4 Receiver Instructions	7
3.5 Receiver Installation Instructions	8
3.6 Charging Case Instructions	9
Chapter 4 FAQ	9
Chapter 5 Packing List	10
Chapter 6 Specification	11

Chapter 1 Product Introduction

1.1 Appearance



Transmitter LARK 100 TX



Charging case



Receiver LARK 100 RX

1.2 Introduction

LARK microphone, mainly oriented to the education industry, is used for sound reinforcement or recording and broadcasting scenarios when teachers are teaching. Based on 2.4G wireless transmission technology, it creates an interference-free lecture environment for teachers, and the device has high performance and stability. Built-in intelligent algorithms such as Acoustic Feedback Cancellation, Automatic Gain Control, Adaptive Noise Suppression, and Room Acoustic Calibration allow teachers to deliver every word clearly to every student without having to worry about the sound being loud or soft. The microphone used in the solution is very small and light to wear; compared to traditional handheld microphones, the microphone allows teachers to free their hands and give full play to body language; compared to far-field microphones, the microphone has better sound quality and allows teachers to move around and pick up a wider range of sound.

A set of LARK microphones includes a charging compartment, a transmitter and a receiver. The charging case can quickly recharge the transmitter, and the receiver supports both UAC digital output and two analog outputs.

1.3 Product Features

Transmitter main features:

- Used for teacher-teaching scenarios, based on 2.4G wireless technology;
- No range anxiety, Li-ion battery lasts 4 hours;

- Configuration of fast charging case, can continuously charge the microphone more than three times;
- Very compact, with a diameter of 32mm and a thickness of 13.8mm;
- Ultra-lightweight design, weighing only 10.5g;
- Two wearing styles (lavalier and headwear with magnetic accessories, can be freely switched), interaction is easier;
- Multi-room use, eliminate crosstalk (any microphone can be paired with any receiver);
- One teacher, one microphone, clean and hygienic;
- Simple operation, only one on button;
- Optional accessories include magnetic headwear and external antenna.

Receiver main features:

- 86 box design, easy to install;
- DSP audio processing with built-in Acoustic Feedback Cancellation, Automatic Gain Control, Adaptive Noise Suppression, and Room Acoustic Calibration algorithms;
- Automatic frequency pairing near power on, automatic disconnection after power off;
- The wireless receiver supports UAC digital output and analog output.

Chapter 2 Usage Scenarios

2.1 General classroom sound reinforcement scenes

General purpose classrooms are usually small enough to allow the receiver to be connected directly to the active speakers.

For easy storage and management, a charging case can be placed on the lectern.

The receiver has two analog outputs, one for audio playback and the other can be used for recorded playback.

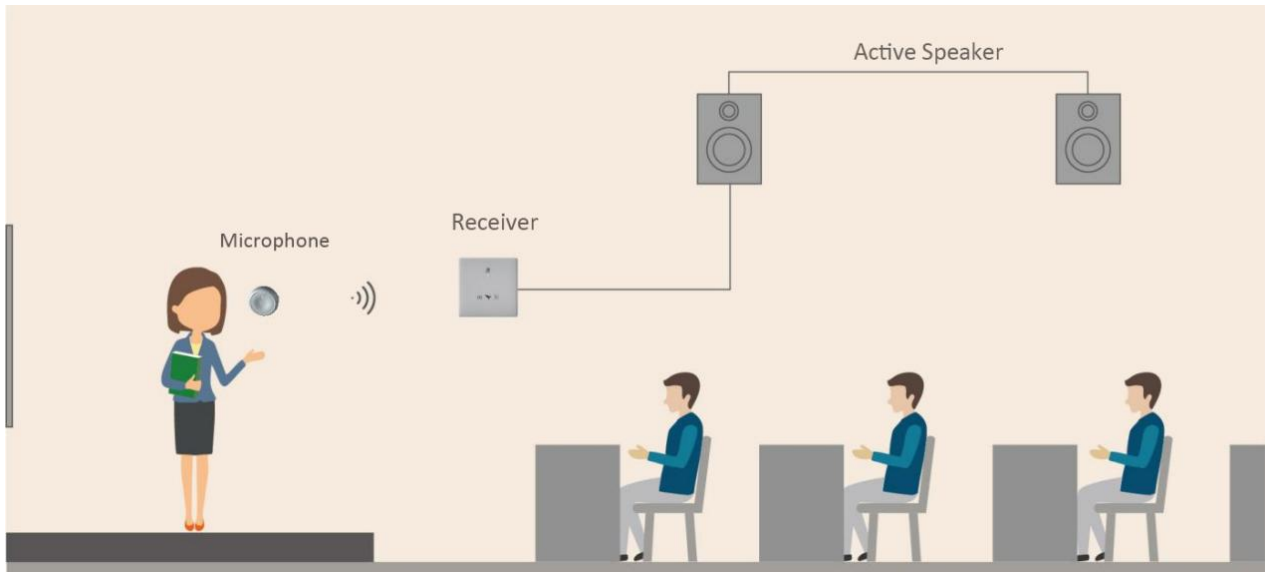

2.2 Lecture theatre sound reinforcement Scenes

Lecture theatre are usually large enough to allow the receiver to be connected to a professional amplifier and further to passive speakers.

For easy storage and management, a charging case can be placed on the lectern.

The receiver has two analog outputs, one for audio playback and the other can be used for recorded playback.

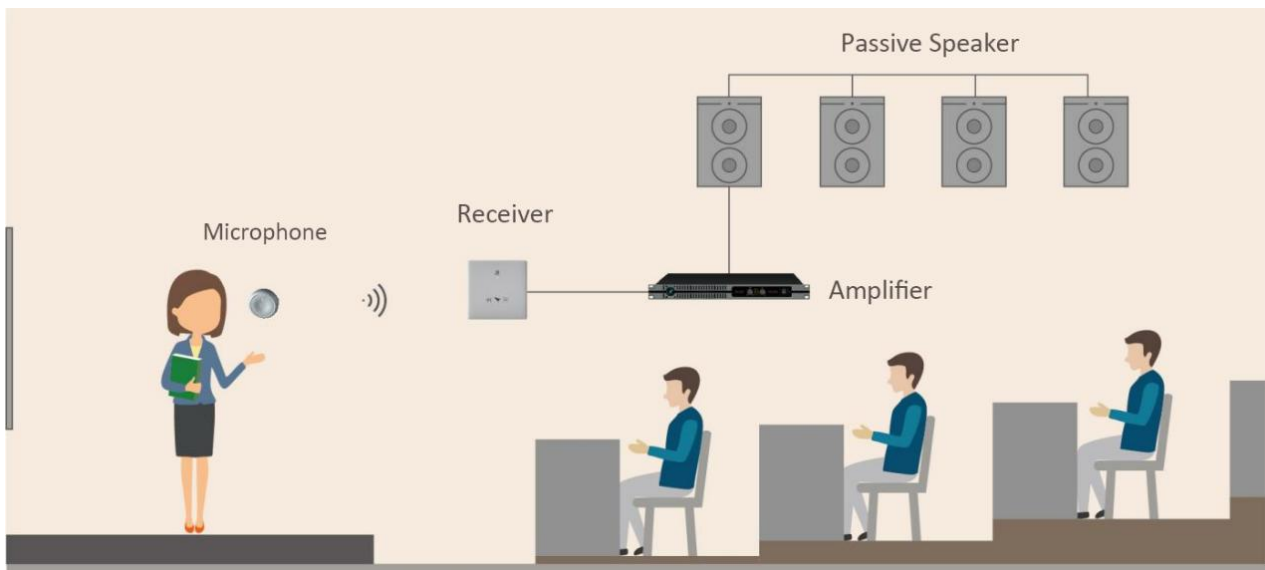

Chapter 3 Operating Instructions

3.1 Usage Process

1. **Power on:** Long press the transmitter button for 2 seconds, the green light of the transmitter blinks to indicate that it is powered on and not paired.
2. **Pairing:** Bring the **front** side of the transmitter close to the NFC sensing area of the receiver, the receiver beeps after successful pairing with a voice prompt and both the transmitter and receiver show a green light always on.

Note:

- 1) **After the transmitter is disconnected, you need to approach the NFC sensor area of the receiver again to re-pair;**
 - 2) **The receiver does not receive NFC sensing when the green light is always on, but only when the green light is flashing .**
3. **Mute:** Short press the transmitter button once, the speaker will emit a "beep" sound with a voice prompt, the red light of the transmitter is always on, which means it is muted; short press the transmitter button once more, simultaneously play voice prompts, the green light of the transmitter is always on, which means it is working.
 4. **Power Off:** Long press the transmitter button for 2 seconds to power off; or directly into the charging case, automatic power off.
 5. **Transmitter charging:** Type-C interface charging; or put it into the charging case for charging.

3.2 Transmitter Instructions

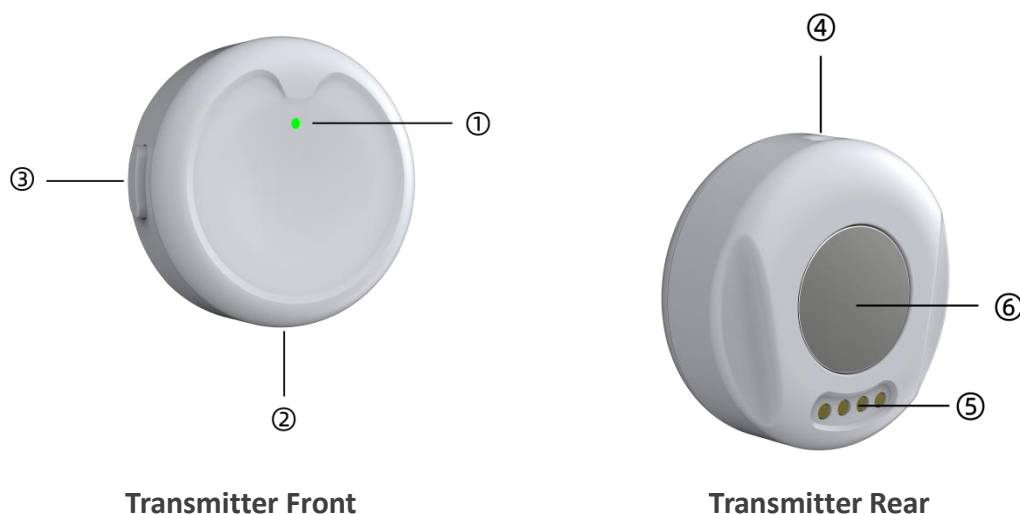

- ① **LED Light:** Green light flashing means not connected with the receiver; green light always on means successfully connected with the receiver and can work normally; red light always on means mute; yellow light always on means low power. yellow light flashing means charging when charging in Type-C interface; yellow light off means full power. The LED light is off when the charging case is charging;
- ② **Type-C Interface:** Charge the transmitter;
Note: It needs to be charged by a 5V 1A charger, or a charger that supports the 5V voltage standard, otherwise the transmitter will be damaged.
- ③ **Button:**
 - 1) **Power On/Off:** Press and hold the button to turn the device on or off;
 - 2) **Mute:** Press the button briefly to switch to mute mode or restore sound, accompanied by a voice prompt;
 - 3) **Room Acoustic Calibration:** When transmitter and receiver are connected, rapidly press the button four times consecutively to trigger Room Acoustic Calibration. The system will automatically calibrate based on acoustic characteristics (including speaker and room environment), with voice prompts before and after calibration. Rapidly press the button six times consecutively to toggle Room Acoustic Calibration on/off, accompanied by a voice prompt.
- ④ **Microphone Pickup Hole:** In order to ensure a better sound pickup effect, the pickup hole should be aligned with the sound emitting part when wearing it;
- ⑤ **Charging Pins:** Charging in the charging case through the charging contact;
- ⑥ **Magnetic Area:** Support magnetic headwear accessories, magnetic collar clip accessories, magnetic gasket accessories.

3.3 How to Wear the Transmitter

3.3.1 Wear magnetic lavalier

Attach the standard magnetic lavalier to the transmitter; the transmitter can then be clipped directly onto your collar for use.

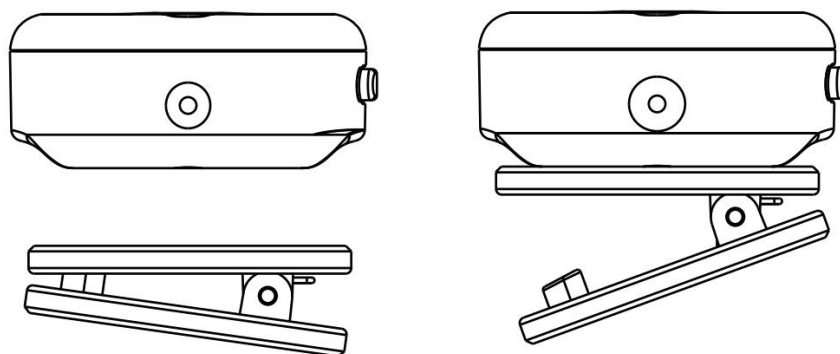

3.3.2 Wear magnetic spacer

Place the included magnetic spacer inside your clothing; the transmitter will attach to your clothing via the spacer's magnet.

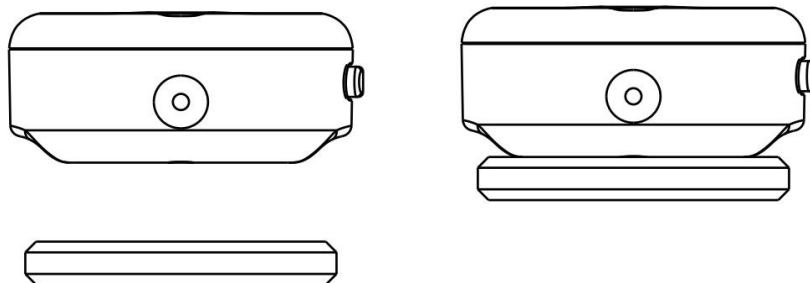

3.3.3 Magnetic headset/Neck hanging wear

Attach the transmitter magnet to the magnetic headset; the transmitter can be worn on the head or around the neck.

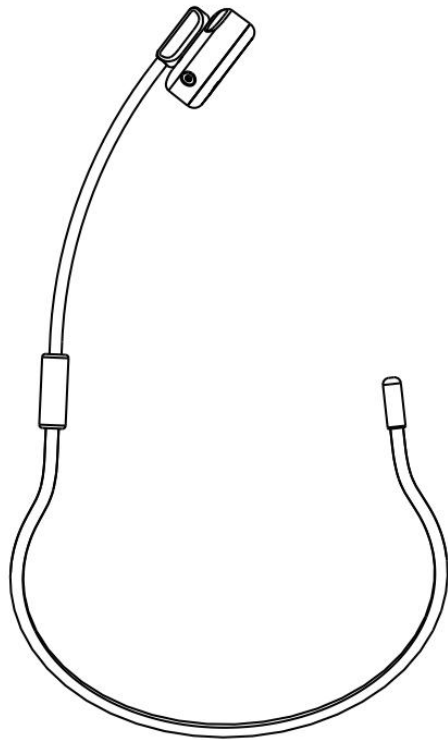

Headset wearing direction

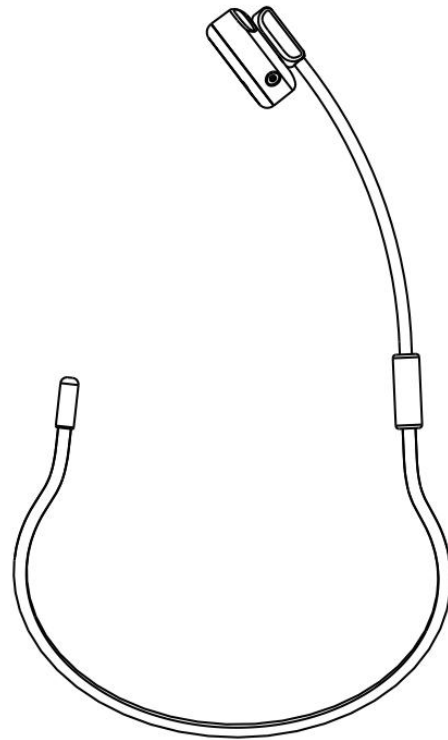

Hanging neck wearing direction

3.4 Receiver Instructions



Transmitter Front

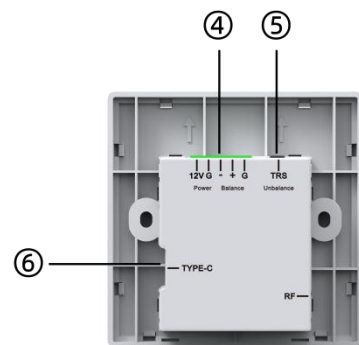

Receiver Rear

- ① **LED Light:** Green light flashing means not connected with the transmitter; green light always on means successfully connected with the transmitter and can work normally;
- ② **NFC:** Support NFC induction pairing function, the **front** of the transmitter is close to here for pairing;
- ③ **Buzzer:** Beeps when the transmitter and receiver are paired successfully;
- ④ **Balanced Signal and 12V Power Interface:** 5Pin Phoenix terminal, of which 3Pin ("-", "+", "G") output balanced signal, 2Pin ("12V", "G") connect to DC 12V power supply;

- ⑤ **3.5mm TRS Interface:** Output stereo single-ended analog audio signal to active speakers or recording and broadcasting host;
- ⑥ **Type-C Interface:** For power supply, also supports digital audio output of UAC protocol.

3.5 Receiver Installation Instructions

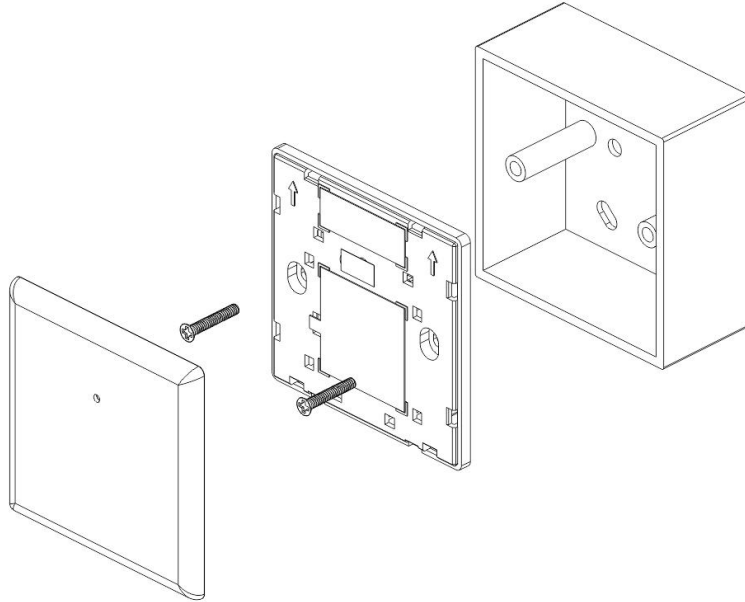

- ① Wiring the audio cable and power cord to the 86 box;
- ② Remove the receiver cover plate;
- ③ Connect the audio cable and power cord to the receiver ports;
- ④ Align the receiver with the 86 box, then close and secure it with two screws;
- ⑤ Replace the receiver cover plate.

3.6 Charging Case Instructions

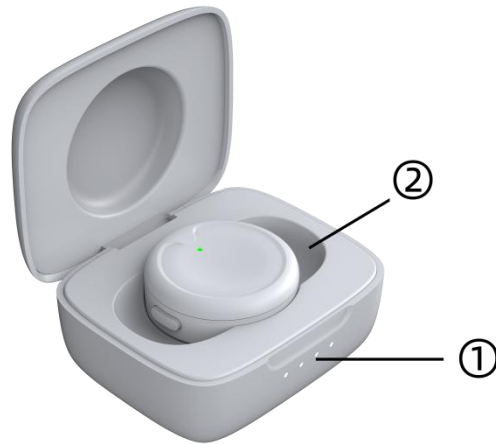

- ① **White LEDs:** 4 white LEDs indicate different power levels of the charging compartment, when opening/closing the cover, the white LEDs flash 2 times and light up for 5 seconds and then go out. When the transmitter is put into the charging case for successful charging, the white LED light flashes 2 times for 5 seconds and then goes out;
- ② The charging case has a magnetic suction function, which supports magnetic suction charging.

Note: If the transmitter is put into the charging case and the 4 white LEDs don't flash, it means that the transmitter contacts are not aligned with the charging case contacts, you need to re-adjust the position of putting it into the charging case so that it is aligned with the charging case contacts.

Chapter 4 FAQ

Problem	Solution
Receiver and transmitter pairing fails after power up	<ul style="list-style-type: none"> A. Place the front of the transmitter close to the NFC sensing area of the receiver; B. Pair the transmitter in the NFC recognition zone of the receiver, if the pairing fails the first time, you can try to adjust the position in the recognition zone to recognize it again.

No sound from the microphone when in use	<p>A. Check whether the indicator lights of the receiver and transmitter are green, green means normal operation;</p> <p>B. Check whether the indicator lights of the receiver and transmitter are red, red means mute, you can click the transmitter button to exit the mute mode;</p> <p>C. Check if the indicator light of the transmitter is not on, not on means it is not turned on or has no power, it needs to be turned on or charged in time.</p> <p>D. Detect whether the external amplifier is working normally.</p>
Microphone sound is getting low or sporadic	Check the microphone indicator to see if it is yellow, yellow indicates low power and needs to be recharged in time.
General Troubleshooting	Restart the device.

Chapter 5 Packing List

NO.	Name	Quantities
1	Transmitter (Microphone) LARK 100 TX	1
2	Charging Case	1
3	Receiver LARK 100 RX	1
4	Magnetic Lavalier	1
5	Magnetic Spacer	1
6	Type-C Cable	1

7	Storage Bag	1
8	Quick Guide	1
9	Magnetic Headwear (optional)	1
10	Certificate of Conformity	1
11	Warranty Card	1

Chapter 6 Specification

Transmitter Parameters	
Transmission Mode	2.4G
Polarity Mode	Omnidirectional
Operating distance (without obstacles)	30 meters
RF Output Power	10dBm
Frequency Response	100Hz~20kHz
Sample Rate	48KHz
Bit Depth	16-bit
Signal-to-noise ratio	≥80dB
Built-in Battery Capacity	97mAh
Power supply mode	Built-in lithium battery power supply, charging case pins charging
Endurance	About 4 hours

Charging time	About 1 hours
Weight	10.5g
Dimension	32mm×32mm×13.8mm
Operating Temperature and Humidity	0°C ~ 50°C, 10%~90%RH, No condensation

Charging case Parameters	
Battery Capacity	300mAh
Power Supply Method	Power supply via charging case contacts
Power Supply Times to TX	>3
Charging Time	About 1 hours
Weight	39g
Dimensions	60.3mm×50.1mm×28.4mm
Operating Temperature and Humidity	0°C ~ 50°C, 10%~90%RH, No condensation

Receiver Parameters	
Transmission Mode	2.4G
Operating Distance (without obstacles)	30 Meters
RF Output Power	10dBm
Frequency Response	100Hz~20kHz

Sample Rate	48KHz
Bit Depth	16-bit
Signal-to-Noise Ratio	≥ 80dB
Audio Output	UAC digital; Balanced analog (Phoenix terminal); Unbalanced analog (3.5mm TRS)
Power Supply	DC 12V or USB Type-C Powered
Weight	30g
Dimension	86.1mm×86.1mm×27.3mm
Operating Temperature and Humidity	0°C~40°C, 10%~90%RH, No condensation
Storage Temperature	-10°C~50°C
Package Dimensions (L×W×H)	280mm×210mm×70mm
Package Weight	0.5kg

Warranty Regulations

The warranty period of this product is 1 year.

In the warranty period of non-man-made damage caused by the product performance failure can enjoy three packages of service.

Warranty card by the sales unit stamped after the effective. The alteration is invalid!

The following conditions (including, but not limited to, this) are not covered by the three-package service:

1. No warranty card or missing valid invoice or the date has exceeded the validity period of the three packages of services;
2. Not in accordance with the requirements of the product instructions for use, maintenance, management and damage caused;
3. The product model or code on the warranty voucher does not match the physical goods;
4. Damage caused by the dismantling and repair of non-authorized service providers;
5. Normal discoloration, wear and tear and consumption during the use of the product are not covered by the warranty;
6. The product cannot be used due to the user's own network reasons, please consult customer service staff.



SHENZHEN S TRACK SCIENCE TECHNOLOGY CO., LTD

Web: www.s-track.com.cn

Tel: +86 755 29983191

Mail: service@s-track.cn

Add: 9F, 1B, Shangzhi Technology Park, Guangming District, Shenzhen City, Guangdong Province, China 518107